

**CERTIFIED MAXIMUM FLOW RATE:  
FLOOR-1,664 GPM      WALL-N/A**

**GRATE DETAIL**

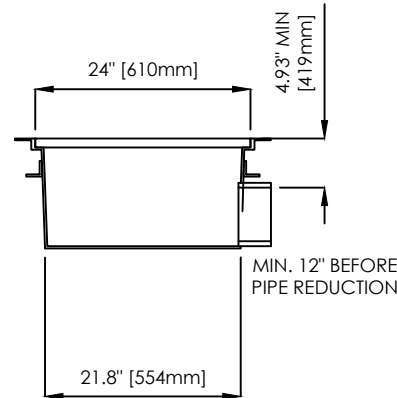
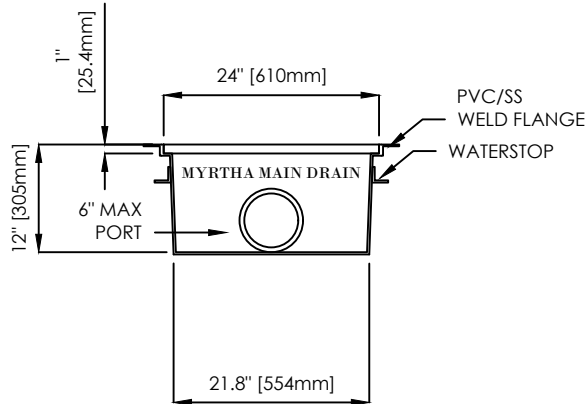
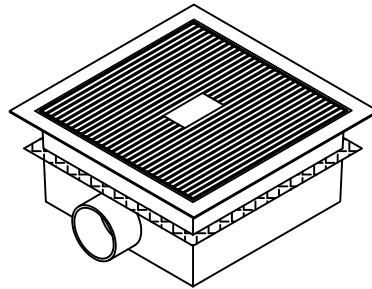
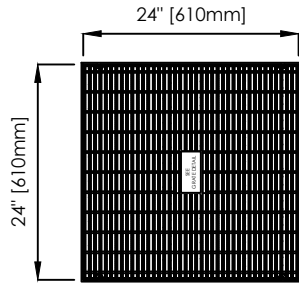

**SUMP AND GRATE:** UNBLOCKABLE SOFA CERTIFIED TO APSP/ANSI/ICC-16 2017, NSF/ANSI/CAN 50-2020, AND USPC. RPD FIELD CERTIFICATION IS NOT REQUIRED. CORROSION RESISTANT, NON-CONDUCTIVE, NON-MAGNETIC, AND REQUIRES NO BONDING.

**SUMP:** FABRICATED WITH 8-OZ FIBERGLASS MAT AND WHITE MARINE GRADE GEL COAT (APPLIED INSIDE ONLY). A 2" PVC/SS WELD FLANGE, A 1.5-IN FRP WATER STOP IS LOCATED 5-IN BELOW TOP LIP OF SUMP AND A 1.5-IN FRP BRACE IS APPLIED, BOTH AROUND THE OUTSIDE PERIMETER. TWO (2) 2-IN SCH-40 FEMALE THREADED ADAPTERS ARE INSTALLED STANDARD ON THE BOTTOM OF THE SUMP FOR HYDROSTATIC VALVE CONNECTION. THE MAXIMUM SIDE PORT SIZE IS 12-IN, AND PORT SIZES > 12-IN ARE PERMITTED TO BE LOCATED ON THE BOTTOM. ANY CONFIGURATION OF MULTIPLE PORTS OF ANY SIZE IS PERMITTED PROVIDED ALL SIDE PORTS ARE <= 12-IN. THE CERTIFIED MAXIMUM FLOW RATE FOR THE SOFA MUST NOT BE EXCEEDED. "DALDORADO" IS STENCILED ON THE BODY, AND MARKING REQUIRED BY STANDARDS IS IMPRINTED ON THE LEDGE. OPTIONAL WATER STOPS ON PORTS, MOUNTING UNISTRUTS, AND PORT GUSSETS ARE AVAILABLE. PORTS MAY BE SCH-40 OR SCH-80, TYPE SLIP COUPLING, THREADED FEMALE ADAPTER, OR FLANGE COUPLING.

**GRATE:** ONE (1) FLAT 24-IN X 24-IN GRATES FORMED OF UV-STABILIZED MOLDED PVC, CERTIFIED TO APSP/ANSI/ICC-16 2017, NSF/ANSI/CAN 50-2020, AND USPC. THE TOP SURFACE OF THE GRATE HAS A TEXTURED DESIGN FOR SLIP RESISTANCE. GRATE SECTIONS ARE 0.20-IN (5MM) WIDE AND 1-IN (25.4MM) AVG. DEPTH FOR LOAD STRENGTH REQUIREMENTS. SPACE BETWEEN GRATE BARS DOES NOT EXCEED 0.39-IN (10MM). GRATE PROVIDES A MINIMUM 62% OPEN AREA FOR UNRESTRICTED WATER FLOW. THE MANUFACTURE DATE AND MARKING REQUIRED BY STANDARDS IS MOLDED INTO EACH GRATE.

**INSTALLATION:** FOLLOW DALDORADO SUPPLIED INSTALLATION INSTRUCTIONS AND WARNINGS. GRATE MUST BE INSTALLED WITHIN SUMP USING ONLY THE 316 SS 3/4"-20x1.25" MACHINE SCREWS (TESTED TO APSP/ANSI/ICC-16 2017) AS SUPPLIED BY DALDORADO. NO OTHERS ARE PERMITTED.

**MULTIPLE PORT CONFIGURATION MAXIMUM FLOW RATES PER PORT:**  
**EACH 6-IN PORT: 1664 GPM**  
**EACH 4-IN PORT: 712 GPM**  
**EACH 3-IN PORT: 408 GPM**

**SUMP LIFE: LIFE OF THE AQUATIC FACILITY**  
**GRATES AND FASTENERS: 25 YEAR SERVICE LIFE/10 YEAR WARRANTY**

DalMAX-MBD-242412-06 OPTIONS		
TOTAL GPM	1664 FLOOR, N/A WALL	
PORT CONFIGURATIONS	ANY PER NOTES ABOVE	
PIPE SCHEDULE-PVC	40	80
MAX PORT SIZE, SIDE	6-IN	
OPTIONAL 2" FEMALE ADAPTER FOR HYDROSTATIC VALVE	YES	NO
GRATE COLOR	WHITE	
ANY P.O. SUBMITTAL MUST BE ATTACHED TO ORDER FORM		

All drawing are saved in a \*.dwg format and are provided as a service to our customers; dimensions supplied by Daldorado are for reference only. Daldorado or any authorized distributor of our products will not be held responsible from files which have been converted and does not warranty the documents against deficiencies or typographical errors of any kind. All measurements of the actual product must be verified before any custom fabrication in the field occurs. COPYRIGHT: This document is the property of Daldorado, LLC and is provided on an in-confidence basis, it may not be copied or reproduced without the permission of Daldorado or its authorized agent.

4327 Arnold Avenue, Naples, FL 34104 Phone: (888) 509-8128 www.daldorado.com

Product:	24x24x12 Sump & Grate Package	
Product #:	DalMAX-MBD-242412-06	
Material:	FG/PVC	Rev Date: 07/20/2022
Color:	WHITE	Rev By: Daldorado

