

GRATE DETAIL

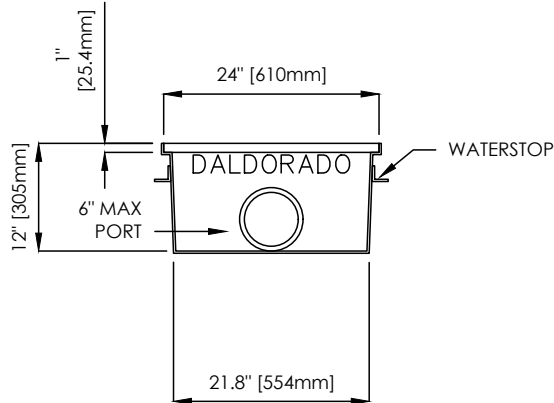

**CERTIFIED MAXIMUM FLOW RATE:
FLOOR-1,664 GPM WALL-N/A**

DRAIN ASSEMBLY RATED FOR ONE (1) 6" PORT, ONLY

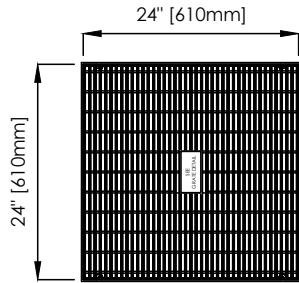
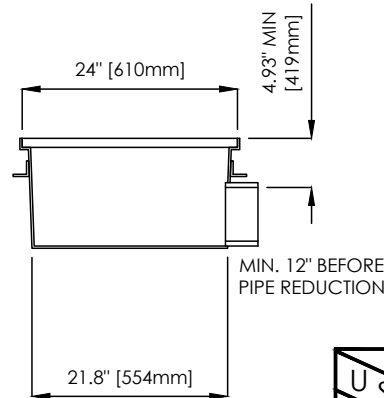
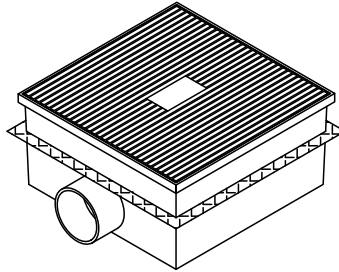

This DALMAX-SG-242412 sump certified by IAPMO R&T against NSF/ANSI/CAN Standard 50 for Aquatic Facilities. For indoor and outdoor use. www.IAPMO.com

SUMP AND GRATE: UNBLOCKABLE SOFA CERTIFIED TO APSP/ANSI/ICC-16 2017, NSF/ANSI/CAN 50-2020, AND USPC. RPD FIELD CERTIFICATION IS NOT REQUIRED. CORROSION RESISTANT, NON-CONDUCTIVE, NON-MAGNETIC, AND REQUIRES NO BONDING.

SUMP: FABRICATED WITH 8-OZ FIBERGLASS MAT AND WHITE MARINE GRADE GEL COAT (APPLIED INSIDE ONLY). A 1.5-IN FRP WATER STOP IS LOCATED 4-IN BELOW TOP LIP OF SUMP AROUND THE OUTSIDE PERIMETER. AN OPTIONAL 2-IN SCH-40 FEMALE THREADED ADAPTER IS AVAILABLE ON THE BOTTOM OF THE SUMP FOR HYDROSTATIC VALVE CONNECTION. THE MAXIMUM SIDE PORT SIZE IS 6-IN. THE MINIMUM SUCTION PIPE OPENING LENGTH BEFORE SIZE REDUCTION IS 12-IN. THE CERTIFIED MAXIMUM FLOW RATE FOR THE SOFA MUST NOT BE EXCEEDED.

"DALDORADO" IS STENCILED ON THE BODY, AND MARKING REQUIRED BY STANDARDS IS IMPRINTED ON THE LEDGE. PORTS MAY BE SCH-40 OR SCH-80, TYPE SLIP COUPLING, THREADED FEMALE ADAPTER, OR FLANGE COUPLING.

GRATE: ONE (1) FLAT 24-IN X 24-IN GRATES FORMED OF UV-STABILIZED MOLDED PVC, CERTIFIED TO APSP/ANSI/ICC-16 2017, NSF/ANSI/CAN 50-2020, AND USPC. THE TOP SURFACE OF THE GRATE HAS A TEXTURED DESIGN FOR SLIP RESISTANCE. GRATE SECTIONS ARE 0.20-IN (5MM) WIDE AND 1-IN (25.4MM) AVG. DEPTH FOR LOAD STRENGTH REQUIREMENTS. SPACE BETWEEN GRATE BARS DOES NOT EXCEED 0.39-IN (10MM). GRATE PROVIDES A MINIMUM 62% OPEN AREA FOR UNRESTRICTED WATER FLOW. THE MANUFACTURE DATE AND MARKING REQUIRED BY STANDARDS IS MOLDED INTO EACH GRATE.

INSTALLATION: FOLLOW DALDORADO SUPPLIED INSTALLATION INSTRUCTIONS AND WARNINGS. GRATE MUST BE INSTALLED WITHIN SUMP USING ONLY THE 316 SS 1/4"-20x1.25" MACHINE SCREWS (TESTED TO APSP/ANSI/ICC-16 2017) AS SUPPLIED BY DALDORADO. NO OTHERS ARE PERMITTED.

DalMAX-SG-242412-06 OPTIONS

| | | |
|---|----------------------|----|
| TOTAL GPM | 1664 FLOOR, N/A WALL | |
| PIPE SCHEDULE-PVC | 40 | 80 |
| MAX PORT SIZE | 6-IN | |
| OPTIONAL 2" FEMALE ADAPTER FOR HYDROSTATIC VALVE | YES | NO |
| GRATE COLOR | WHITE | |
| ANY P.O. SUBMITTAL MUST BE ATTACHED TO ORDER FORM | | |

**SUMP LIFE: LIFE OF THE AQUATIC FACILITY
GRATES AND FASTENERS: 25 YEAR SERVICE LIFE/10 YEAR WARRANTY**

All drawing are saved in a *.dwg format and are provided as a service to our customers; dimensions supplied by Daldorado are for reference only. Daldorado or any authorized distributor of our products will not be held responsible from files which have been converted and does not warranty the documents against deficiencies or typographical errors of any kind. All measurements of the actual product must be verified before any custom fabrication in the field occurs. COPYRIGHT: This document is the property of Daldorado, LLC and is provided on an in-confidence basis, it may not be copied or reproduced without the permission of Daldorado or its authorized agent.

Product: 24x24x12 Sump & Grate Package

Product #: DalMAX-SG-242412-06

Material: FG/PVC Rev Date: 05/15/2026

Color: WHITE Rev By: RJG

DALDORADO

2900 Horseshor Dr. S, Naples, FL 34104
Phone: 888.509.8128
www.daldorado.com