

**DalLUX STONE AND TILE SUPPORTS:** ALL COMPONENTS ARE CORROSION RESISTANT, NON-CONDUCTIVE, NON-MAGNETIC, AND DO NOT REQUIRE BONDING. THE DALDOARDO DalLUX SUPPORTS ARE PROVIDED IN 12-IN UNIT LENGTHS AND 12-IN WIDTHS. THE SUPPORTS ARE FORMED OF MOLDED UV-STABILIZED PVC IN MODULE INTERLOCKING SECTIONS, CERTIFIED TO NSF/ANSI/CAN 50-2020 AND BS EN 13451 COMPLIANT FOR CHILD FINGER AND TOE ENTRAPMENT.

**LOAD:** CERTIFIED LOAD CLASSIFICATIONS UNDER IBC STANDARD AS 3996 CLASS, "A" AS OVER 10kN (=2,248-LBS-FORCE) FOR GRATES AND COVERS.

**CORNERS:** CORNERS ARE FABRICATED AND SUPPLIED IN 45-DEG, 90-DEG AND SPECIAL-ORDER CORNERS TO PROJECT REQUIREMENTS.

**COLOR:** GRATE IS PROVIDED IN BLACK ONLY.

**OPEN AREA:** 10.5%, FLOW RATE = 70 GPM @ 1.5 FPS GRAVITY FLOW.

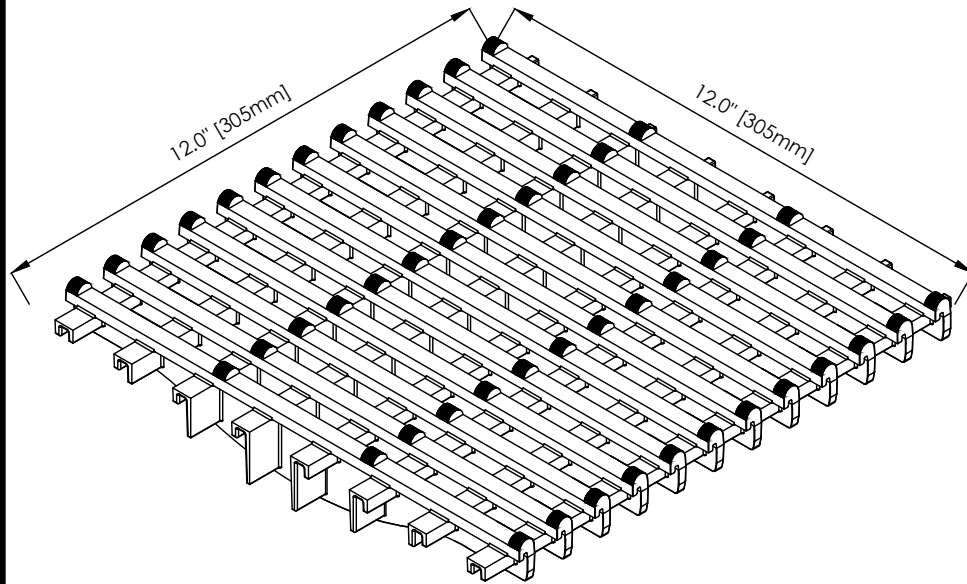

PLAN VIEW

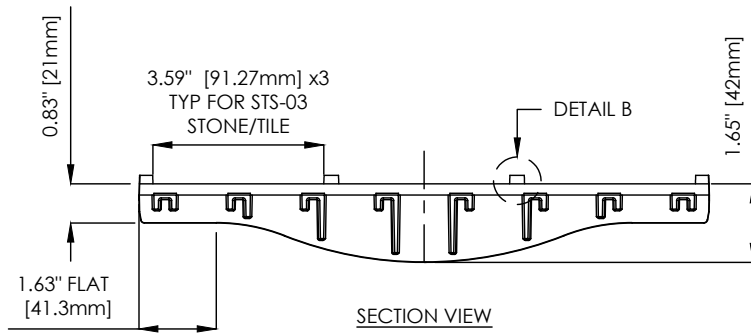

SECTION VIEW  
ACROSS GUTTER

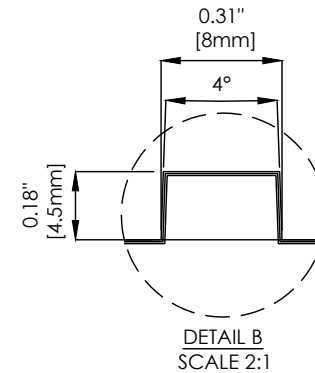

DETAIL B  
SCALE 2:1

DalLUX STONE AND TILE SUPPORTS - DalLUX-ST5-03-BK	
LINEAR FEET	
# 90-DEG CORNERS (OUTSIDE)	
# 90-DEG CORNERS (INSIDE)	
# SPECIAL CORNERS	
SLOPE IF APPLICABLE	YES:
GRATING COLOR	BLACK
*WRITE IN OR CIRCLE APPLICABLE INFORMATION	

All drawing are saved in a \*.dwg format and are provided as a service to our customers; dimensions supplied by Daldorado are for reference only. Daldorado or any authorized distributor of our products will not be held responsible from files which have been converted and does not warranty the documents against deficiencies or typographical errors of any kind. All measurements of the actual product must be verified before any custom fabrication in the field occurs. COPYRIGHT: This document is the property of Daldorado, LLC and is provided on an in-confidence basis, it may not be copied or reproduced without the permission of Daldorado or its authorized agent.

Product: DalLUX Stone and Tile Support	
Product #: DalLUX-ST5-03-BK	
Material: PVC	Rev Date: 05/06/2026
Color: BLACK	Rev By: RJG

**DALDORADO**

2900 Horseshoe Dr. S, Naples, FL 34104  
Phone: 888.509.8128  
www.daldorado.com