

DaIFLEX

A LANE LINE ANCHOR UNIT
LENGTH VARIES (12, 14, 16 inches)

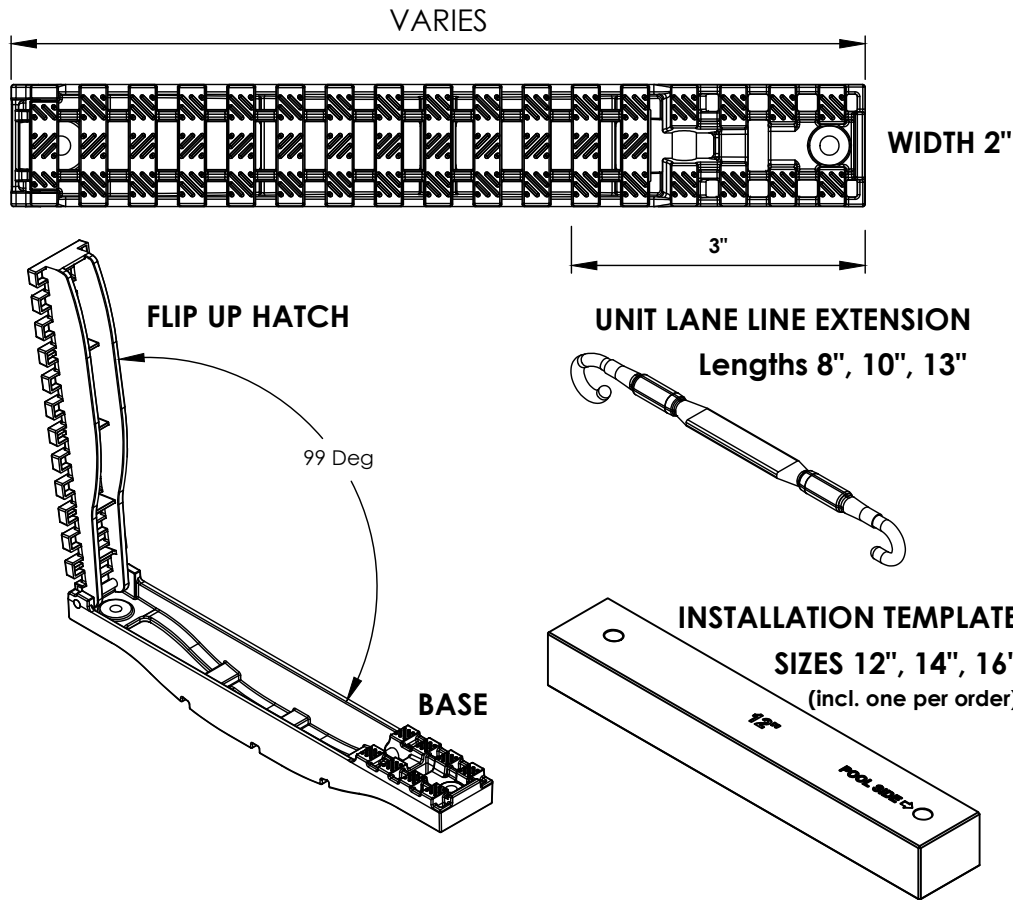

DaIFLEX-LANE-LINE-ANCHOR UNIT
PATENT PENDING 63/438,739

This DaIFLEX Grates certified by IAPMO R&T against NSF/ ANSI/CAN Standard 50 for Aquatic Facilities. For indoor and outdoor use. www.IAPMO.com

DaIFLEX:

- A LANE LINE ANCHOR UNIT THAT IS NON CORROSIVE AND DOES NOT REQUIRE BONDING. THE UNIT IS FORMED OF TWO MOLDED PVC SECTIONS CERTIFIED ANSI/NSF/CAN 50-2020 SECTION 22.3 AND A LANE LINE EXTENSION.
- THE UNIT IS MADE OF TWO SECTIONS, A BASE SECTION WITH 316SS PIN CONNECTION TO A FLIP UP TOP GRATE SECTION WITH A RAISED HERRINGBONE DESIGN CERTIFIED TO AS 4585-2013 CLASS C FOR WET BAREFOOT SLIP RESISTANCE. THE GRATE SECTIONS ARE CERTIFIED FOR VERTICAL AND PULL LOADS AND FINGER AND LIMB ENTRAPMENT PER SECTION 3 OF ANSI/ APSP-16 2017 UNDER ANSI/ NSF-50 2020.
- UNIT LANE LINE EXTENSION IS CONSTRUCTED OF A 316SS BRAIDED STRAP COVERED WITH BLACK SILICON THAT IS FLEXIBLE AND IS STOWED IN THE UNIT BASE WHEN NOT IN USE. THE LANE LINE EXTENSION IS CAPABLE OF EXTENDING BEYOND THE UNIT AND THE POOL EDGE TO CONNECT TO THE 'S'-HOCK OF THE SWIM LANE LINE.
- DESIGNED TO MINIMISE USE OF METALS AND COMPLIES WITH NEC 680.26 (c) REQUIREMENT TO AVOID ELECTRICAL BONDING. DaIFLEX LOAD PULL TESTED TO 1,200LB. DaIFLEX SUPPLIED WITH INSTALLATIO HARDWARE AND DRILL TEMPLATE.

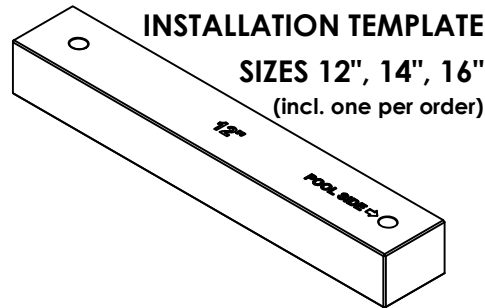

| DaIFLEX-LANE-LINE-ANCHOR-UNIT ORDER REQUEST | | | |
|---|---------------|---------------|---------------|
| UNIT LENGTH | 12" | 14" | 16" |
| UNIT COLOR | White Gray | White Gray | White Gray |
| EXTENSION LENGTH | 8" | 10" | 13" |

All drawing are saved in a *.dwg format and are provided as a service to our customers; dimensions supplied by Daldorado are for reference only. Daldorado or any authorized distributor of our products will not be held responsible from files which have been converted and does not warranty the documents against deficiencies or typographical errors of any kind. All measurements of the actual product must be verified before any custom fabrication in the field occurs. COPYRIGHT: This document is the property of Daldorado, LLC and is provided on an in-confidence basis, it may not be copied or reproduced without the permission of Daldorado or its authorized agent.

| | | | |
|------------|--------------------------|----------------------|--|
| Product: | DaIFLEX-LANE-LINE-ANCHOR | | DALDORADO 2900 Horseshow Dr S, Naples, FL 34104 Phone: 888.509.8128 www.daldorado.com |
| Product #: | DaIFLEX-LLA-XX | | |
| Material: | PVC | Rev Date: 04/30/2026 | |
| Color: | WHITE/GRAY | Rev By: RJG | |